

FreeSpace® 3 subwoofer/satellite systems



Key Features

- **Subwoofer/satellite** systems that deliver high fidelity and extended-bandwidth reproduction of voice and music for a wide range of installed applications, including retail, restaurant and hospitality operations
- **Modular design** supports the flexibility for use of 2 or 4 satellites per Acoustimass bass module, and parallel connection of bass modules
- **Mix and match** surface-mount and flush-mount components to work with different room decors and layouts for a variety of applications
- **Flush-mount** components are plenum rated when used with the optional plenum cover
- **Selectable 70/100V** or low impedance with transformer tap adjustment on Acoustimass bass module
- **Can be configured** for stereo or mono operation



TECHNICAL DATA SHEET

Product Overview

The Bose® FreeSpace® 3 subwoofer/satellite systems are high-performance, extended-range loudspeaker systems designed for small to medium-sized installed applications requiring high fidelity and extended bandwidth reproduction of voice and music. Surface and flush components can be mixed and matched to provide greater flexibility to suit a wide range of applications. FreeSpace® 3 systems feature a wide coverage pattern and frequency response down to 40 Hz.

Technical Specifications

System Performance				
	System	Satellites	Acoustimass Module	
Frequency Response (+/-3 dB) ¹	50 Hz - 16 kHz	210 Hz - 16 kHz	50 Hz - 230 Hz	
Frequency Range (-10 dB) ¹	40 Hz - 20 kHz	170 Hz - 20 kHz	40 Hz - 315 Hz	
Nominal Dispersion	See components	70° conical	Omni-directional below 200 Hz	
Recommended High-Pass Filter	40 Hz high-pass filter	N/A	40 Hz high-pass filter	
Loudspeaker EQ	Recommended	Recommended	Recommended	
Overload Protection	PTC	N/A	PTC	
Long-Term Power Handling ²	70/100 V: 200 W (800 W peak) Low impedance: 100 W (400 W peak)	12 W (48 W peak)	70/100 V: 200 W (800 W peak) mono Low impedance: 50 W (200 W peak) per channel stereo or 100 W (400 W peak) mono	
Sensitivity (SPL / 1 W @ 1 m) ³	82 dB SPL	84 dB SPL	Per channel: 76 dB SPL (Mono: 79 dB SPL)	
Maximum SPL @ 1 m ⁴	93 dB (99 dB SPL peak in a 45,000 ft² room, with RT60 of 1 second, +/- 3 dB)	Pink noise: 95 dB SPL (101 dB SPL peak) IEC noise: 92 dB SPL (108 dB SPL peak)	Per channel: 96 dB SPL (102 dB SPL peak) Mono: 102 dB SPL (108 dB SPL peak)	
Nominal Impedance	4-Cube System: 6 Ω per channel 2-Cube System: 5 Ω per channel (surface); 6 Ω per channel (flush)	6 Ω	Surface Acoustimass: 5 Ω mono direct Flush Acoustimass: 6 Ω mono direct (transformer bypassed)	
Transformer Taps (70/100 V)	25 W, 50 W, 100 W, 200 W	N/A	25 W, 50 W, 100 W, 200 W	
Transducers				
	Satellites	Acoustimass Module		
Driver Complement	2.5" (64 mm) full-range driver (per satellite)	5.25" (133 mm) dual voice coil low frequency driver		
Physical				
	Surface	Flush	Surface	Flush
Enclosure	High-impact polystyrene, textured	PC/ABS	High-density wood composite with solid color PVC laminate	PC/ABS
Grille	Cloth grille	Expanded metal grille	N/A	Expanded metal grille
Environmental	Indoor use only	Indoor use only	Indoor use only	Indoor use only
Connectors	2-position screw type barrier	2-position terminal block	Screw terminal	Multi-position screw-type barriers
Suspension / Mounting	Wall mount brackets included. Bracket Angles: ±30° pitch, ±90° yaw	Integral quick-install mounting features included. Tab for seismic chain or safety cable	Wall bracket (attached to module) included	Integral quick-install mounting features. Three points at rear of housing for pendant mounting
Dimensions	3.0" x 3.0" x 4.0" (77 mm x 77 mm x 102 mm) Depth w/ bracket: 5.9" (149 mm)	Outer flange dia.: 6.2" (157 mm) Depth: 4.8" (123 mm) Ceiling hole dia.: 5.0" (127 mm)	14.0" x 7.5" x 13.6" (356 mm x 191 mm x 345 mm) Width w/ bracket: 8.8" (222 mm)	Outer flange dia.: 15.4" (391 mm) Depth: 7.4" (189 mm) Ceiling hole dia.: 14.3" (362 mm)
Ceiling Thickness (Maximum)	N/A	1.5" (38 mm)	N/A	1.8" (48 mm)
Net Weight	1.8 lb (0.8 kg)	1.9 lb (0.9 kg)	17.5 lb (7.9 kg)	14.0 lb (6.4 kg)
Shipping Weight	4.0 lb (1.8 kg)	5.0 lb (2.3 kg)	25.0 lb (11.3 kg)	20.0 lb (9.1 kg)

FreeSpace[®] 3 subwoofer/satellite systems



Product Code	Satellites		Acoustimass Module	
	Surface	Flush	Surface	Flush
Black	040144 - pair	040150 - pair	040146	040148
White	040143 - pair	040149 - pair	040145	040147

Footnotes:

- 1 Frequency response and range measured on-axis with recommended active EQ in an anechoic environment.
- 2 Power handling tested using pink noise filtered to meet IEC 268-5, 6 dB crest factor, 100 hours, with recommended EQ.
- 3 Sensitivity measured in free field (no boundary-loading gain) with recommended active EQ, referenced to 1W/1m.
- 4 Maximum SPL calculated from sensitivity and power handling specifications, exclusive of power compression.

TECHNICAL DATA SHEET

Impedance

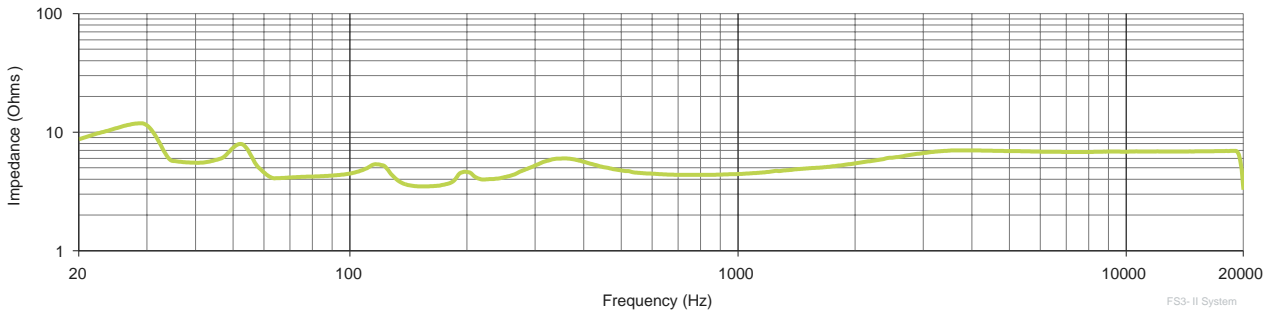

On-Axis Response

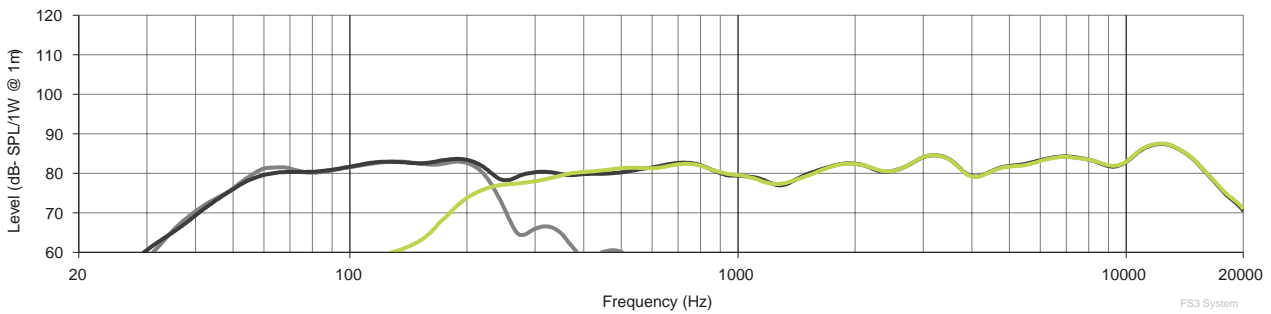

Tap Chart

FreeSpace 3 System Tap Chart							
Mount	m	2.4	3.0	3.6	4.2	4.8	
Height	ft	8	10	12	14	16	
T A P	25	87	86	86	85	84	dB _{SPL}
	50	90	89	89	88	87	
	100	93	92	92	91	90	
	200	96	95	95	94	93	

Mechanical Diagrams

Surface Satellite

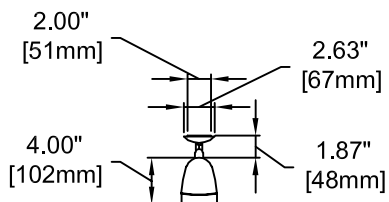

Top View

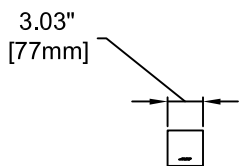

Front View

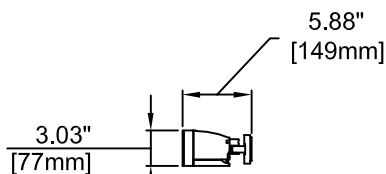

Right View

Surface Acoustimass

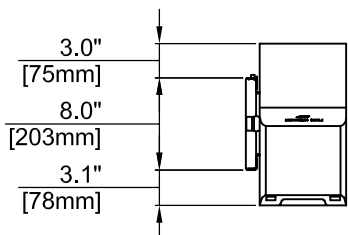

Back View

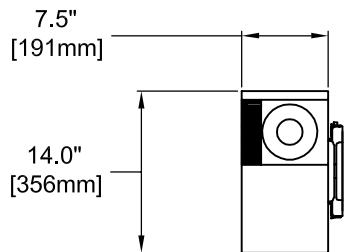

Front View

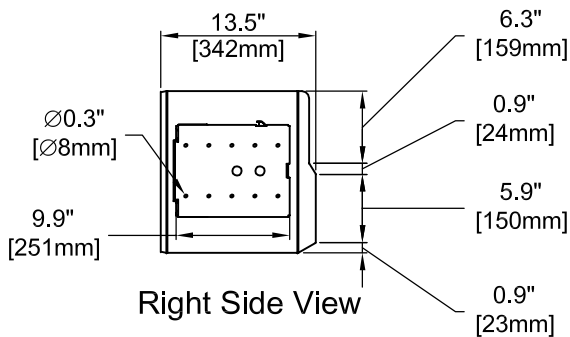

Right Side View

FreeSpace[®] 3 subwoofer/satellite systems



Flush Satellite

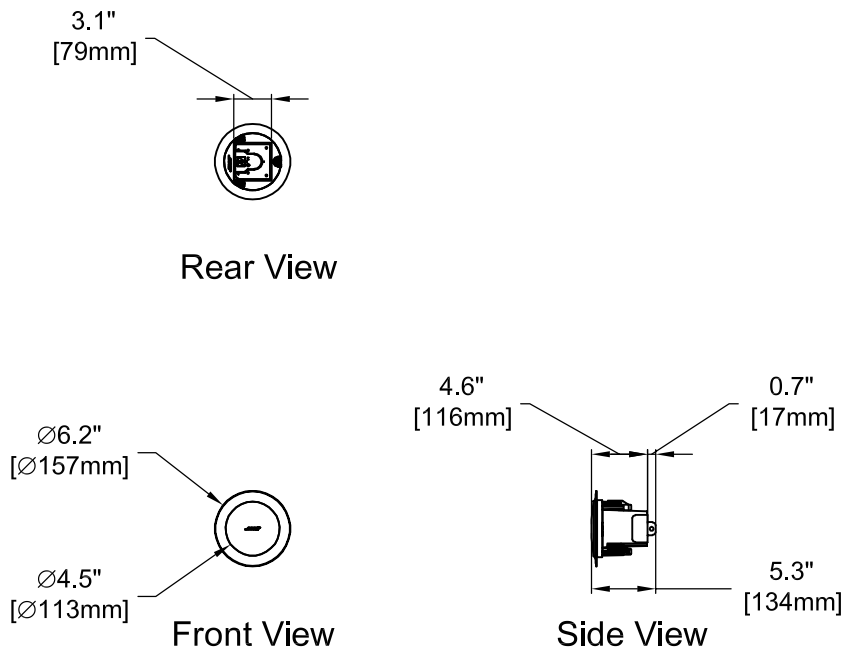

Flush Acoustimass

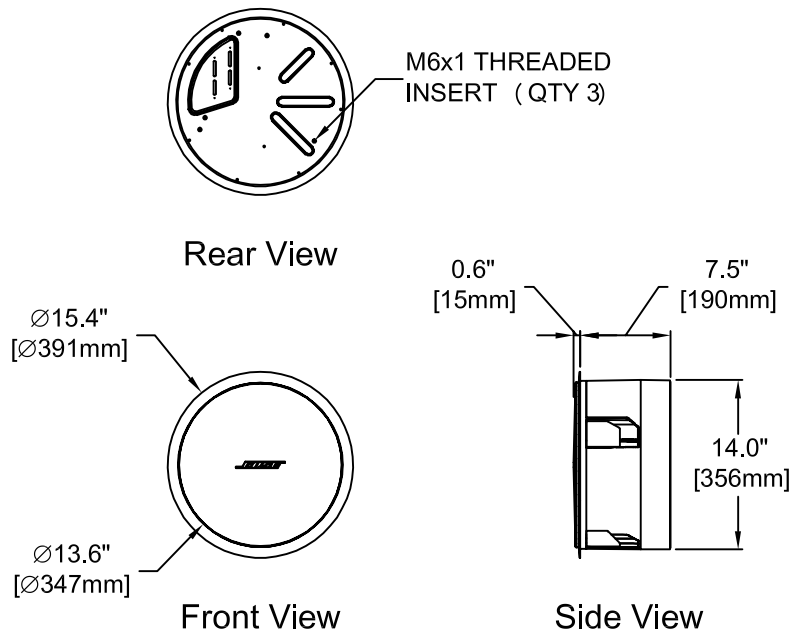

Horizontal Plots – Flush Satellite

250 Hz Octave Band

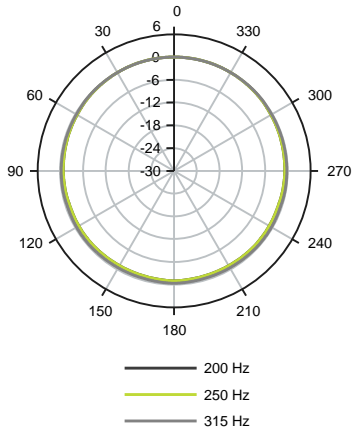

500 Hz Octave Band

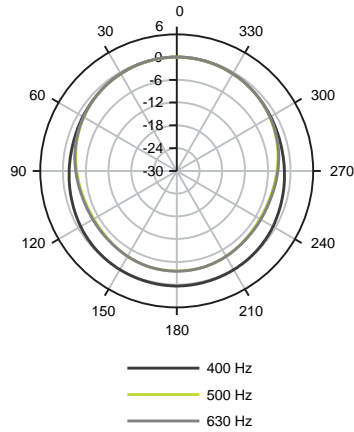

1000 Hz Octave Band

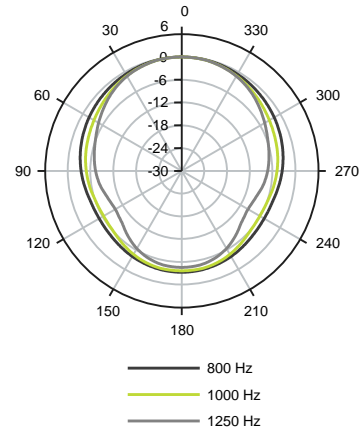

2000 Hz Octave Band

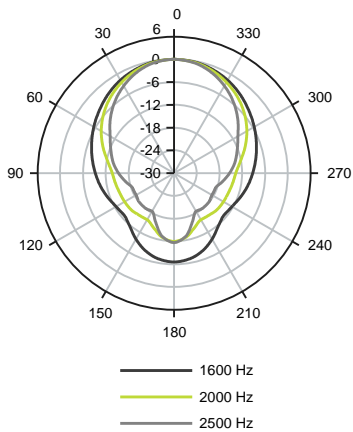

4000 Hz Octave Band

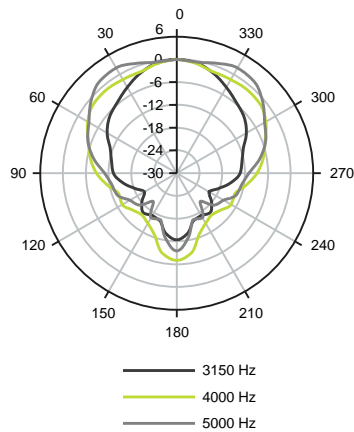

8000 Hz Octave Band

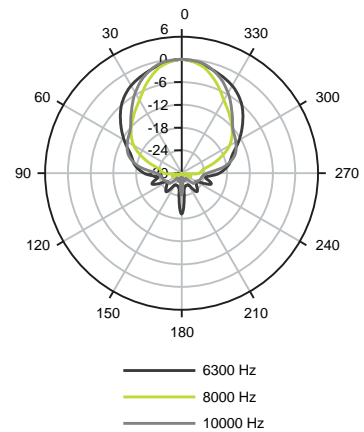

16000 Hz Octave Band

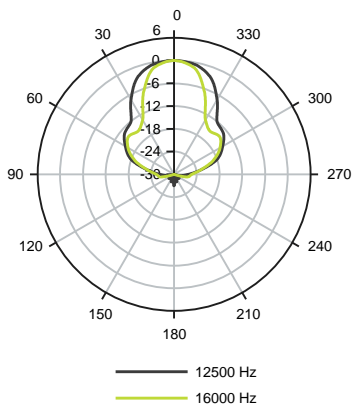

FS3 SAT

Vertical Plots – Flush Satellite

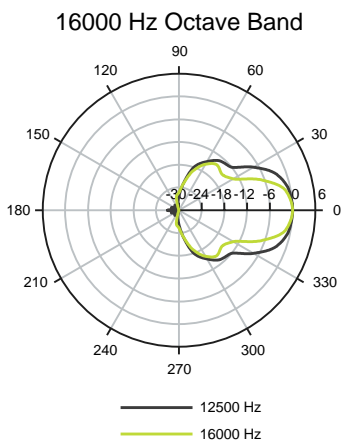
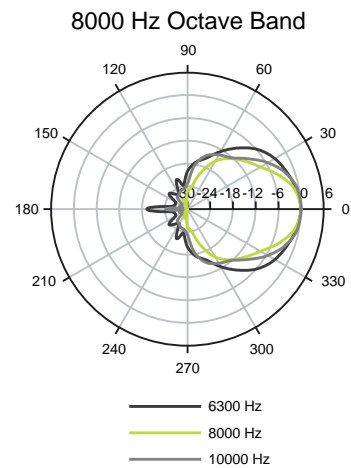
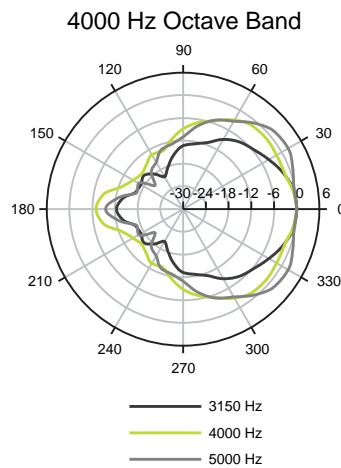
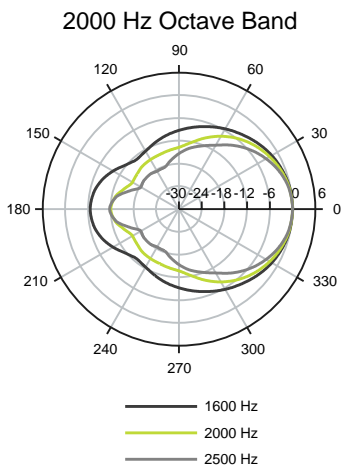
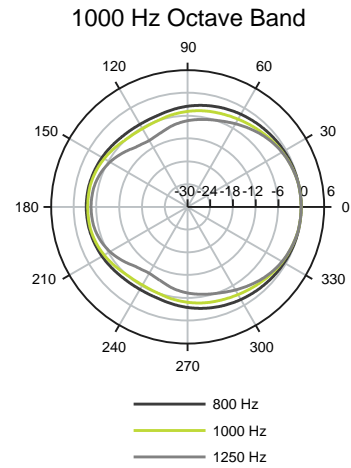
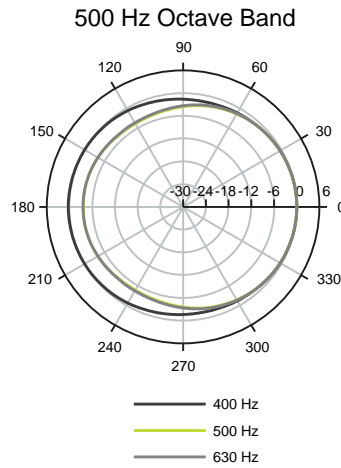
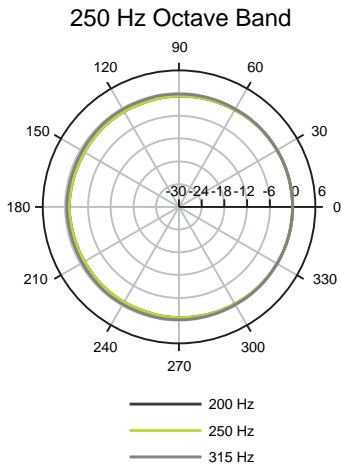

FS3 SAT

Horizontal Plots – Surface Satellite

250 Hz Octave Band

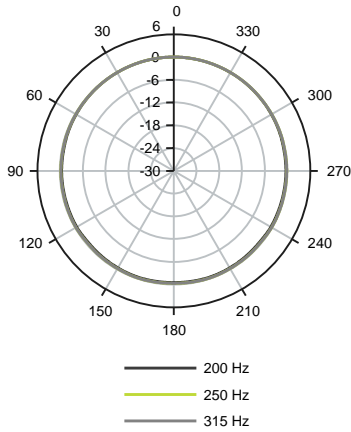

500 Hz Octave Band

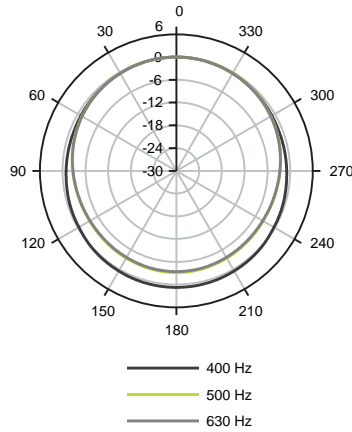

1000 Hz Octave Band

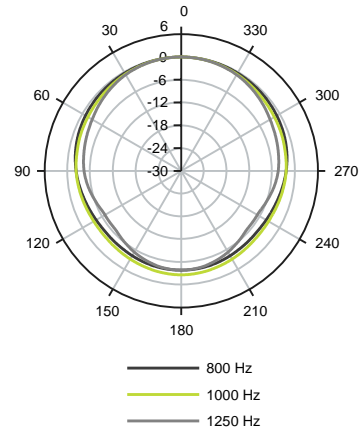

2000 Hz Octave Band

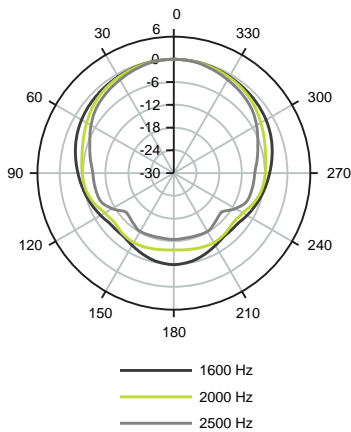

4000 Hz Octave Band

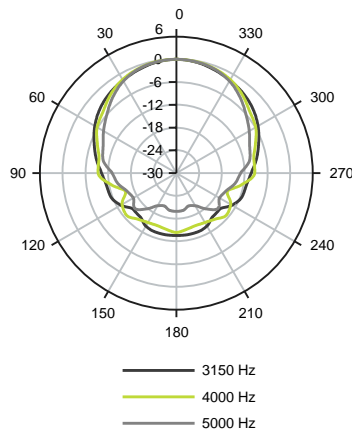

8000 Hz Octave Band

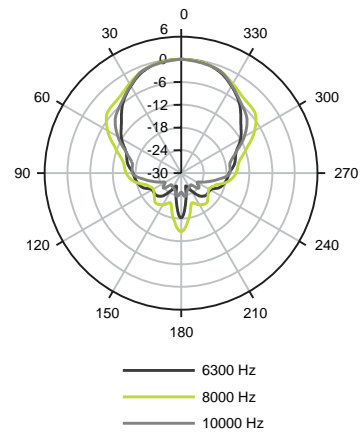

16000 Hz Octave Band

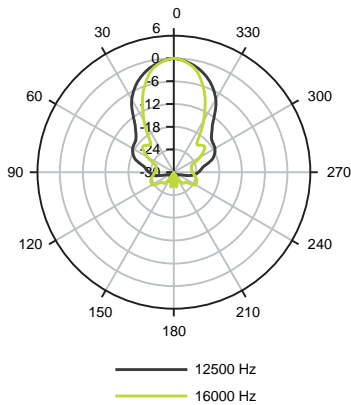

FS3 SAT S

Vertical Plots – Surface Satellite

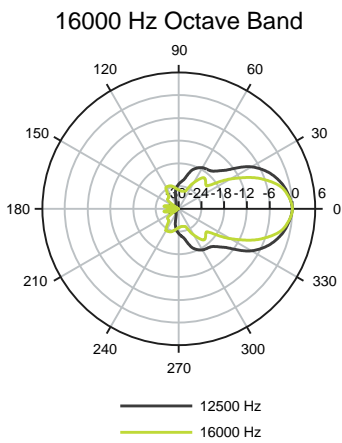
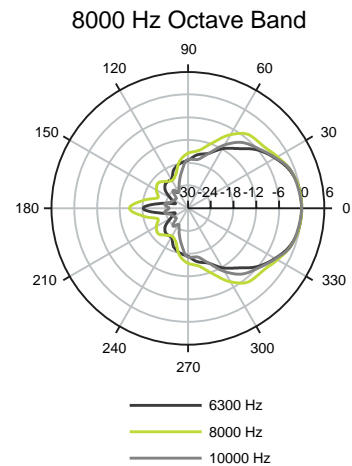
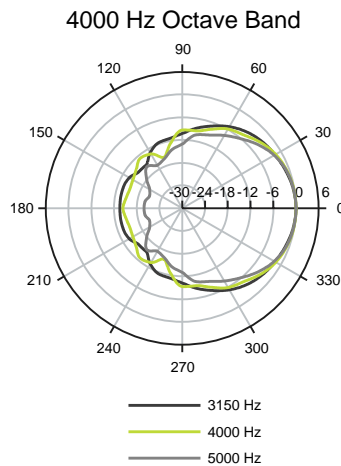
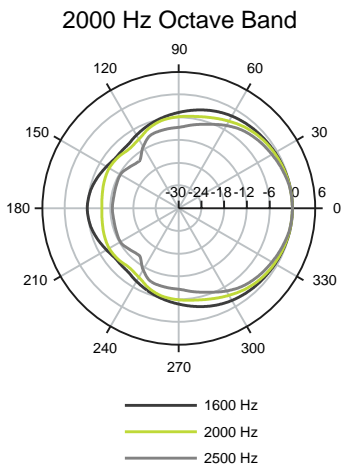
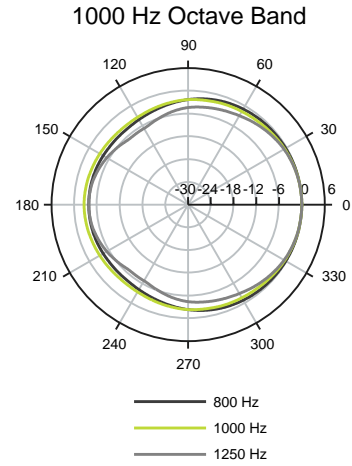
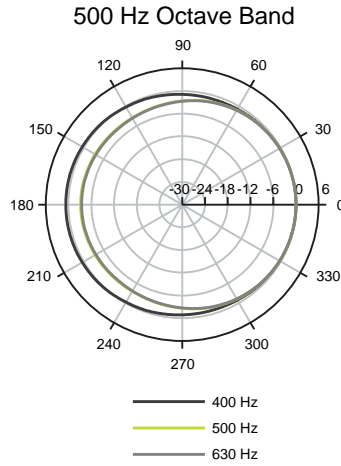
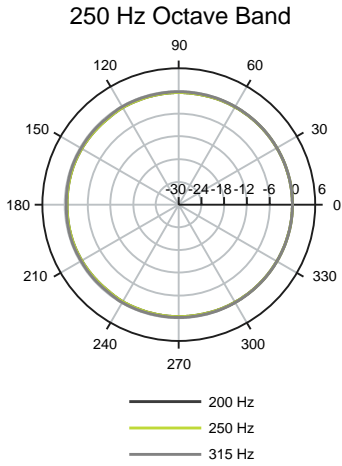

FS3 SAT S

FreeSpace® 3 subwoofer/satellite systems



Architects' and Engineers' Specifications

The loudspeaker system shall be a 200 watt ported loudspeaker system that includes one Acoustimass® module and two or four satellite speakers. It shall be capable of producing 93 dB SPL average in a 45,000 ft³ room with an RT60 of 1 second in a range of 50 Hz to 16 kHz (±3 dB).

The module shall have one 5.25" (133 mm) dual voice coil low frequency driver. The module shall have an input impedance of 6 ohms (5 ohms for surface-mount module) for direct connection to un-equalized low impedance amplifier sources. The system shall be configured for use with either a 70/100 V input or a low impedance input. The transformer shall offer multiple taps of 25 W, 50 W, 100 W, and 200 W.

Each satellite speaker shall have one 2.5" (64 mm) full-range driver. The nominal average dispersion shall be 170° at -6 dB.

The input connectors shall consist of multi-position screw-type barriers on the flush-mount Acoustimass module, a spring-type barrier connector for the 70/100 V inputs and a screw-type barrier strip for direct 4-8 ohm input on the surface-mount Acoustimass module, a two position guillotine connector on the flush-mount satellite, and a two position screw-type barrier on the surface-mount satellite. Wire jumpers for transformer settings shall be provided. Removable covers shall shield all bass module input and jumper connections.

The flush-mount Acoustimass module shall have dimensions of 15.4" (391 mm) outer flange diameter; 14.25" (361 mm) ceiling hole diameter; and 7.5" (190 mm) height to top of housing. It shall weigh 14 lb (6.36 kg). The surface-mount Acoustimass module shall have dimensions of 14.0" H x 8.7" W (w/bracket) x 13.6" D (356 mm x 221 mm x 345 mm) and shall weigh 17.5 lb (7.9 kg) with attached mounting bracket. Each flush-mount satellite speaker shall measure 6.2" (157 mm) outer flange diameter; 5.0" (127 mm) ceiling hole diameter; and 5.0" (127 mm) to top of housing. It shall weigh 1.9 lb (0.9 kg). Each surface-mount satellite speaker shall measure 3.0" H x 3.0" W x 4.0" D (77 mm x 77 mm x 102 mm) and shall weigh 1.75 lb (0.8 kg).

The flush-mount Acoustimass module and flush-mount satellite enclosures shall be composed of PC/ABS with an expanded metal grille and shall meet plenum ratings when used with a plenum cover. The surface-mount Acoustimass enclosure shall be composed of high-density wood composite with solid color PVC laminate, black or white. The surface-mount satellite shall have a cloth grille and black or white polymer finish.

The loudspeaker shall be the Bose® FreeSpace® 3 loudspeaker system.

Safety and Regulatory Compliance

The Bose FreeSpace® 3 system loudspeakers have passed extensive testing and comply with the following specifications and uses:

UL1480 listed:

- General-Purpose Use, UL Category UEAY, File Number S 5591

Air-handling spaces (ceiling plenums), FS3 flush-mount module and flush-mount satellite:

- UL-2043 When used with the PCFS3F and PC-FS3B Plenum Cover accessories
- NFPA-70 National Electric Code 2002, Article 300-22(c)
- NFPA-90-A-1996 Installation of Air Conditioning and Ventilation Systems, Section 2-3.10.1(a), Exception 3

EMC Directive 89/336/EEC and Article 10 (1) of the directive, EN50081-1, and EN50082-1, as signified by the CE mark.